



TRU-WELD Stud Welding

FULL THREAD STUD – FULL WELD BASE

TYPE TT STUD

TYPE F FERRULE SUPPLIED

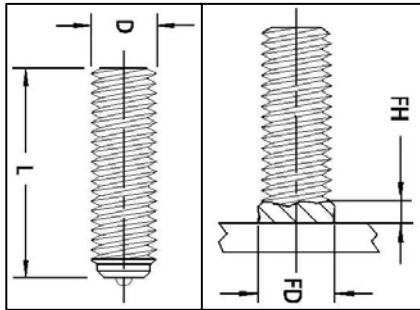

D Stud Diameter	L Length (BW)	TRU-WELD Part Number	FD Weld Fillet Diameter	FH Weld Fillet Height	Ferrule Part Number
1/4-20	3/4	TT04-012-11	23/64	7/64	FER04-F
5/16-18	3/4	TT05-012-11	7/16	7/64	FER05-F
3/8-16	3/4	TT06-012-11	1/2	1/8	FER06-F
7/16-14	7/8	TT07-014-11	19/32	9/64	FER07-F
1/2-13	7/8	TT08-014-11	11/16	5/32	FER08-F
5/8-11	1	TT10-016-11	7/8	3/16	FER10-F
3/4-10	1-3/16	TT12-019-11	1-1/16	1/4	FER12-F
7/8-9	1-11/16	TT14-027-11	1-1/8	5/16	FER14-F
1-8	1-11/16	TT16-027-11	1-3/8	3/8	FER16-F

Mechanical Property Requirements	
Tensile Strength	55,000 psi min.
Yield Strength	50,000 psi min.
Elongation (% in 2 in.)	17% min.
Elongation (% in 5x dia.)	14% min.
Reduction of Area	50% min.

Full Thread Studs are used in all types of applications. They can be welded to a flat surface, or to the inside or outside of an angle.

Length: Length is listed before weld. Stud diameters 1/2" and below will be approx. 1/8" shorter after welding. 5/8" will be approx. 3/16" shorter after welding.

TRU-WELD TT Studs can be made in any length above the standard minimum.

Material: Low carbon steel, ASTM A29, 1010-1020. TT Studs are also available in weldable stainless steel. Type 302 is the most commonly used. Other grades of stainless steel (except Type 303) are available when required.

DIAMETER	CHUCK PART #	Light Duty Standard		Light Duty Split		Standard Combination
		FOOT PART #	GRIP PART #	FOOT PART #	GRIP PART #	FOOT AND GRIP #
1/4	CN-025	B-1N	GN-025	B-1C	GC-025	QN-025
5/16	CN-031	B-1N	GN-031	B-1C	GC-031	QN-031
3/8	CN-037	B-1N	GN-050	B-1C	GC-050	QN-050
7/16	CN-043	B-1N	GN-043	B-1C	GC-043	QN-044
1/2	CN-050	B-1C	GN-062	B-2C	GC-062	QN-062
5/8	CN-062	B-1C	GN-075	B-2C	GC-075	QN-075
3/4	CN-075	B-1C	GN-075	B-2C	GC-075	QN-075
7/8	CN-087	B-3N	GN-087	B-3C	GC-087	QN-087
1	CN-100	B-3N	GN-100	B-3C	GC-100	QN-100

TFP Corporation/TRU-WELD
460 Lake Road
Medina, Ohio 44256

(330) 725-7741
(330) 725-0161 Fax
Sales@tfpcorp.com

<http://www.tfpcorp.com>
<http://www.truweldstudwelding.com>
<http://www.weldstud.com>