

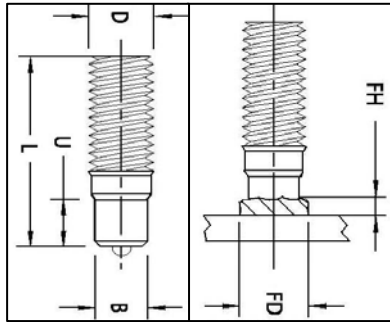

TRU-WELD Stud Welding



THREADED STUD – REDUCED WELD BASE

TYPE TR STUD

TYPE R FERRULE SUPPLIED

D Stud Diameter	L Length (BW)	TRU-WELD Part Number	B Base Diameter	U Base Length	FD Weld Fillet Diameter	FH Weld Fillet Height	Ferrule Part Number
3/8-16	3/4	TR06-012-11	.310	3/8	7/16	7/64	FER06-R
7/16-14	7/8	TR07-014-11	.373	3/8	1/2	1/8	FER07-R
1/2-13	7/8	TR08-014-11	.435	7/16	19/32	9/64	FER08-R
5/8-11	1	TR10-016-11	.500	1/2	11/16	5/32	FER10-R
3/4-10	1-3/16	TR12-019-11	.625	5/8	7/8	3/16	FER12-R

TR Studs are used in all types of applications. They can be welded to a flat surface, or to the inside or outside of an angle.

Length: Length is listed before weld. Stud diameters 1/2" and below will be approx. 1/8" shorter after welding. 5/8" will be approx. 3/16" shorter after welding.

TRU-WELD TR Studs can be made in any length above the standard minimum.

Material: Low carbon steel, ASTM A29, 1010-1020. TR Studs are also available in weldable stainless steel. Type 302 is the most commonly used. Other grades of stainless steel (except Type 303) are available when required

Mechanical Property Requirements

Tensile Strength	55,000 psi min.
Yield Strength	50,000 psi min.
Elongation (% in 2 in.)	17% min.
Elongation (% in 5x dia.)	14% min.
Reduction of Area	50% min.

DIAMETER	CHUCK PART #	Light Duty Standard		Light Duty Split		Standard Combination
		FOOT PART #	GRIP PART #	FOOT PART #	GRIP PART #	FOOT AND GRIP #
3/8	CN-037	B-1N	GN-037	B-1C	GC-037	QN-037
7/16	CN-043	B-1N	GN-043	B-1C	GC-043	QN-044
1/2	CN-050	B-1N	GN-050	B-1C	GC-050	QN-050
5/8	CN-062	B-2N	GN-062	B-2C	GC-062	QN062
3/4	CN-075	B-2N	GN-075	B-2C	GC-075	QN-075